

Packet and APRS Basics

Dr. John A. Allocca, WB2LUA
www.WB2LUA.com

Copyright 2006. Updated 3/3/10

This publication may be reproduced, provided it is reproduced in it's entirety without any changes

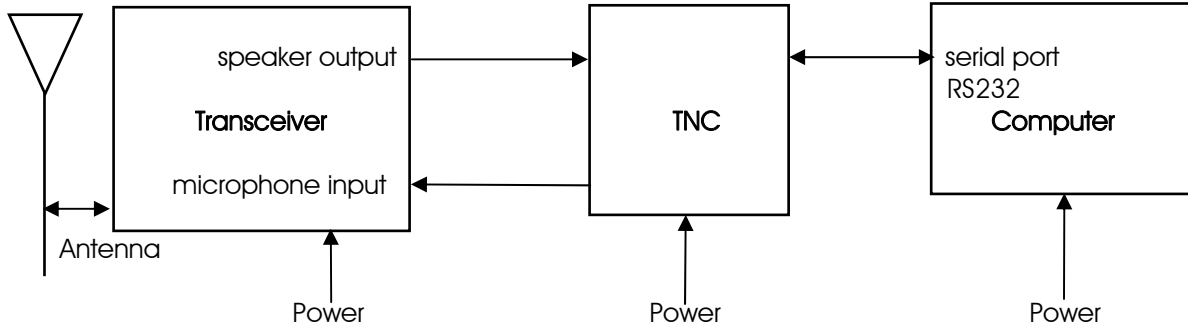

Software

A terminal program is needed to control the data going to and from the TNC and radio. Hyper Terminal, which is supplied with windows works well. Set Hyper Terminal for the com port you are using, which is usually COM1, the speed at which the com port works, which is usually 9600 bps, Data bits = 8, Parity = none, Stop bits = 1. After you complete the settings, save them as "Packet."

There are two communication speeds that are used in Packet Radio 1200 Baud or 9600 Baud. Set the computer serial port to the speed of the computer serial port, usually 9600 Baud. Set the packet system speed to 1200 or 9600 Baud. ABAUD refers to the computer to TNC (serial port), and HBAUD refers to the RADIO or ON-AIR Baud rate (data speed).

Packet Operation

Switch the transceiver ON and turn the volume up a quarter turn or just above the "9:00 o'clock position." Make sure the squelch is not set too tight. The squelch should be set to a position where the transceiver is quiet. The squelch is set in a similar manner that you would use for voice operation. When first turned on, the TNC you may display garbled text on the screen. This is usually because the terminal to TNC baud rate is not set to the same parameters. Some TNC's will do a "search" mode to find the proper settings.

Perform a "control C" [**Ctrl C**] (press Ctrl and the letter C at the same time) to place the TNC into the command (cmd:) mode. This is where all commands are made to and from the TNC. Any command that is typed while in the "cmd: mode is received by the TNC as a direct order. These codes can vary with TNC's.

Once in the command mode, press the [Enter] key. Each time the [Enter] key is pressed a "cmd:" prompt should appear on the screen. This is an indication that the computer has control (command) of the TNC.

All commands must be followed by the [Enter] key.

The next step will be to set the station call sign into the TNC. At the cmd: prompt, type:
MY (your call sign)

Test the TNC to see if the station call sign is set into the TNC. To do so, type:
MY

The screen should display a response from the TNC with:
MYCALL (your call sign)

MYCALL NOCALL indicates that a call sign has never been set, or the internal memory battery has been disconnected or is dead.

To enter your call sign type:

MY (your call sign)

The TNC should respond with:

MYCALL (your call sign)

This indicates that the computer and TNC are communicating properly. If there is no response after typing MY, then try typing:

ECHO ON

The :cmd: should appear on the screen again, with a message similar to the following:

ECHO was OFF

If the computer is displaying double letters, (for example; MMY CCAALLL), this indicates that the ECHO command should be turned OFF. Type the following:

ECHO OFF

The TNC should respond with:

ECHO was ON

Below are some commands that should be made active:

ECHO ON (normal) or ECHO OFF (if double letters are displayed)

MONITOR ON

MCOM ON

MCON OFF (to display only packets addressed to you) or MCON ON (to display all packets)

MRPT ON

If the RS-232 interface cable is wired using the RTS, CTS, Txd, Rxd, and Signal Ground leads, then set the XFLO command OFF. If the RTS, and CTS signals were not used, then make sure the XFLO command is ON.

Note: TNC's have 3 modes of operation: Command, Converse and Transparent. You must remain aware of which mode the TNC is in at any current moment!

Command Mode

In the COMMAND mode, the TNC will interpret data received from the keyboard as a command to process data, not as data to transmit.

When you are in the command mode, the screen will display:

cmd:

Convers (Conversation) Mode

In the CONVERS mode, the TNC will interpret data received from the keyboard as data to be transmitted. Most TNC's will automatically switch to the CONVERS mode after a connection has been established. When you are in the COMMAND mode, you can switch to the CONVERS mode by giving the command:

CONVERS or K

If you are in CONVERS mode and want to switch to COMMAND mode, type:

[Ctrl] C

Monitoring or Calling CQ

If you turn the MONITOR command on, you will see other packet stations on your screen. You will see two call signs at the beginning of each packet separated by a ">" The first station is the station that is sending the packet. The second is the station receiving the packet.

To call CQ, you must be in the CONVERS mode, so that the data received from the keyboard will be interpreted as data to be transmitted.

To enter the CONVERS mode, type:
CONVERS or **K**

Anything you type at this point, will be transmitted.

Example:
W2XYZ CQ CQ CQ

If a station wants to connect to you, they will type the CONNECT W2XYZ command

To return to the COMMAND mode, type:
[Ctrl] C

Packet Direct

The most common frequency for packet communications is 145.010 mhz at 1200 Baud.

Begin in the command mode:
[Ctrl] C

Enter your call sign into the TNC
MY (your call sign)

Test that the TNC has received you call sign:
MY

The screen should display a response from the TNC with:
MYCALL (your call sign)

To connect directly to W2XYZ, assuming you both have a direct path:
CONNECT W2XYZ or **C W2XYZ**

If the TNC receives an acknowledgement of connection it will display:
***** CONNECTED TO W2XYZ**

Once connected, the TNC should automatically switch to conversation mode (CONVERS). You can type in text, then press enter to send. You should automatically receive text from the station you are connected to.

When you have completed your conversation, you need to get back to COMMAND mode to sign off.

To get back to COMMAND mode, type:
[Ctrl] C

To disconnect, type:
DISCONNECT or **D**

The TNC should respond with:
***** DISCONNECTED**

Network NODES

"Nodes" are a vast improvement to the original "digi" scheme. They have gone through many evolutions, starting with the original NETROM, to it's clones TheNET, G8BPQ and MSYS, and finally onto a newer networking protocol called FlexNet. All nodes on Long Island, and most in the surrounding area, now employ the newer faster intelligent FlexNet protocol. Other networking protocols such as ROSE and FPAC never existed in our local area, while use of TCP/IP has faded greatly.

Note, while NETROM and it's clones called a Network Node simply a "NODE" FlexNet, which was developed in Germany called them "DIGI's" based upon the German name for a "Digital Repeater". A "FlexNet DIGI" is what we call a "NODE", not the "digi" described in the digipeating section.

Many packet radio "NODES" connected to the worldwide network exist Long Island:

WA2PNU (145.070 MHz, at 1200 Baud, Huntington)
(M or C WA2PNU-4 for BBS)

NY2LI-8 (145.03 MHz, at 1200 Baud, Hauppauge)

NY2LI (145.05 MHz, at 1200 Baud, Yaphank)

N2NEI (145.07 MHz, at 1200 Baud, Southampton)
(M or C N2NEI-4 for BBS)

K1IMD-2 (144.99 MHz, at 1200 baud, Jamesport)
(M or C N2NEI-4 for BBS)

KC2COJ (145.05 MHz, at 1200 baud, Far Rockaway)
(M OR C KC2COJ-4 for BBS)
(C KC2COJ-1 for TCP/IP Router)

NY2S (145.09 MHz, at 1200 baud, Lynbrook)
(M or C NY2S-4 for BBS)

Frequencies from 144.91 to 145.09 MHz on 2 M, and 441.00 to 441.10 MHz on 70 CM bands are set aside for packet use. There is some additional activity in the 145.59 to 145.69 MHz segment too.

Connecting through a Node

1) To connect to W2XYZ thru node WA2PNU, assuming both stations are listening to WA2PNU node:

C W2XYZ V WA2PNU

2) To connect to W2XYZ thru node NY2LI, assuming your listening to WA2PNU node and W2XYZ is listening to NY2LI node:

C W2XYZ V WA2PNU NY2LI

3) To connect to W2XYZ thru distant node K2JFK (Clay NY), assuming your listening to WA2PNU and W2XYZ is in Clay NY listening to node K2JFK:

C W2XYZ V WA2PNU K2JFK

4) Above examples are from a disconnected state. You can connect first to your local node, C WA2PNU, and then the WA2PNU call can be deleted from the previous examples, such as:

1) **C W2XYZ**

2) **C W2XYZ V NY2LI**

3) **C W2XYZ V K2JFK**

5) To find out what node W2XYZ is monitoring, on an ARRL section by section basis, you connect to any node within that section, and then do a "find".

Example:

F W2XYZ

6) "A" command on any FlexNet will give a manually built list of nodes with geographic locations. Some sites have newer updates than others. "D" gives the machine made <D>estination list, showing callsigns, SSID range, and "round trip times" of other nodes. The D list will always be up to date! Nodes with RTT's under 1000 should be easily connected to, over about 1000 means the path may be dropping out due to propagation conditions.

Example (with your radio set to 145.07 MHz):

C WB2CIK

```
*** CONNECTED to WB2CIK
PC/FlexNet V3.3g West Hills, LI, NY, USA
1200 baud 145.07      9600 baud 145.59
SysOp John C Papson WB2CIK @ WA2PNU
"C WB2CIK-15" to reach me at home keyboard
<C>onnect <D>estinations <F>ind <H>elp <I>nfo <MH>eard <P>orts <Q>uit <U>ers
<A> for Callsign vs Location Table <M>ail will connect to the nearest BBS
```

Disconnecting from a Node

Q for <Q>uit on FlexNet nodes, remember command is B for ye on FBB BBS's!

Example of a Connection to Node and Sending Mail through a BBS

1. Set your call sign

```
cmd:my wb2lua
MYCALL was NOCALL
```

```
cmd:my
MYCALL WB2LUA
```

2. Connect to the nearest Network Node

```
cmd:c wa2pnu
```

```
cmd:*** CONNECTED to WA2PNU
PC/FlexNet V3.3g
Welcome to the WA2PNU Flexnet-Digi node located at Huntington, Suffolk County,
NY [FN30gu] It is operating as part of the USA Eastnet FlexNet Network,
serving the Central Long Island area of the NYC/LI Region.
<LO> for local and additional info.
```

<M> or <C WA2PNU-4> to connect the PBBS.

<D> for available Destinations.

<A> for info on Destination calls.

<H> for Command Summary and Command Explanations in detail.

<I> for System and Additional Information.

```
=>m
```

```
*** connected to WA2PNU-4
[FBB-7.00i-AB1FHMRX$]
```

WA2PNU BBS, QTH FN30GU.
Hello ???, you are now on channel 1.
Here are 318 active messages, 26868 is last message and
26848 is the last you have listed.

Assigned channels:
Ch. 1 (FLEX) : WB2LUA-0 - Wed 03/03/10 20:57
via : WA2PNU-2

This is your first contact with this BBS.
Please enter your first-name :John
City (without ZIP-code !) :11768
Please enter your Home BBS :WA2PNU
Please enter your ZIP code :11768
Thank you...

*** Welcome to the Larkfield Amateur Radio Club (LARK) ***
*** PBBS at Huntington, Suffolk County, NY [FN30gu] ***
*** serving the Central Long Island area of the NLI Region ***

(1) WA2PNU BBS (H for help) >

3. Receive Private mail

(1) WA2PNU BBS (H for help) >

rp wb2lua-0
From : N2PQJ
To : WB2LUA
Type/status : PN
Date/time : 02-Mar 14:02
BID (MID) : 26846_WA2PNU
Message # : 26846
Title : Test Message

(This message has been read 1 times so far in this BBS.)

Test from N2PQJ at 1300 local 03/03/10
/ex

--- End of message #26846 to WB2LUA from N2PQJ ---

3. Send Private mail

(1) WA2PNU BBS (H for help) >
sp kc2ojo
Routing (from WP) to WA2PNU.#NLI.NY.USA.NOAM.
Enter the title for this message to KC2OJO :
test
Enter the text for the message, end with Ctrl-Z or /EX on a blank line) :
test from tonight's meeting
/ex
WA2PNU-4>FBB:26869 P 28 KC2OJO WB2LUA 100303 test

Mid: 26869_WA2PNU Size: 28 bytes

4. Disconnect

[Cntrl C]
cmd: D

Example of a Connection to Node and to another Station

1. Set your call sign

```
cmd:my wb2lua  
MYCALL was NOCALL
```

```
cmd:my  
MYCALL WB2LUA
```

2. Connect to the nearest Network Node

```
cmd:c wa2pnu
```

```
cmd:*** CONNECTED to WA2PNU  
PC/FlexNet V3.3g  
Welcome to the WA2PNU Flexnet-Digi node located at Huntington, Suffolk County,  
NY [FN30gu] It is operating as part of the USA Eastnet FlexNet Network,  
serving the Central Long Island area of the NYC/LI Region.  
<LO> for local and additional info.
```

```
<M> or <C WA2PNU-4> to connect the PBBS.
```

```
<D> for available Destinations.
```

```
<A> for info on Destination calls.
```

```
<H> for Command Summary and Command Explanations in detail.
```

```
<I> for System and Additional Information.
```

```
=>m
```

```
*** connected to WA2PNU-4  
[FBB-7.00i-AB1FHMRX$]  
WA2PNU BBS, QTH FN30GU.  
Hello ???, you are now on channel 1.  
Here are 318 active messages, 26868 is last message and  
26848 is the last you have listed.
```

```
Assigned channels:
```

```
Ch. 1 (FLEX) : WB2LUA-0 - Wed 03/03/10 20:57  
via : WA2PNU-2
```

```
=>c n2pqj  
link setup...q
```

```
=>
```

```
73! *** connect request:N2PQJ VIA WA2PNU-2
```

```
hello
```

```
WA2PNU>N2PQJ:hello
```

```
N2PQJ>WA2PNU:hi john-how is everyone?
```

3. Disconnect

```
[Cntrl C]  
cmd: D  
73!
```

Example of a Connection to Node and to another Node

1. Set your call sign

```
cmd:my wb2lua  
MYCALL was NOCALL
```

```
cmd:my  
MYCALL WB2LUA
```

2. Connect to the nearest Network Node

```
cmd:c wa2pnu
```

```
cmd:*** CONNECTED to WA2PNU  
PC/FlexNet V3.3g  
Welcome to the WA2PNU Flexnet-Digi node located at Huntington, Suffolk County,  
NY [FN30gu] It is operating as part of the USA Eastnet FlexNet Network,  
serving the Central Long Island area of the NYC/LI Region.  
<LO> for local and additional info.
```

<M> or <C WA2PNU-4> to connect the PBBS.

<D> for available Destinations.

<A> for info on Destination calls.

<H> for Command Summary and Command Explanations in detail.

<I> for System and Additional Information.

```
=>c kc2coj
```

```
link setup...
```

```
*** connected to KC2COJ
```

```
PC/FlexNet V3.3g
```

```
Welcome to the KC2COJ Flexnet-Digi node located at Far Rockaway, Queens  
County, NY [FN30co]. It is operating as part of the USA Eastnet Ampnet  
Network, serving the Kings, Queens, Nassau County areas of NYC/LI region.
```

```
<LO> for local and additional info.
```

```
=>
```

3. Disconnect

```
[Cntrl C]  
cmd: D  
73!
```

APRS: Automatic Position Reporting System

Automatic Position Reporting System (APRS) is a packet radio system used for tracking objects, people, vehicles, boats, aircraft, manned/unmanned balloons, weather systems, etc. APRS uses an Amateur Radio mode called unconnected (UI) packets.

APRS was developed by Bob Bruninga WB4APR, and was first introduced to the Amateur Radio Community at the ARRL Computer Networking Conference in New Jersey in 1992. Over the past 10 years APRS usage has grown and expanded across the globe. Many new features and capabilities have been added since its inception. Worldwide, there are over 4000 stations on the map at any one time. There are a number of software programs that can be used to identify and track APRS stations (beacons). I like IU-View32, which works with Street Atlas maps and is very inexpensive. APRS beacons can also be tracked via the internet at www.findu.com.

Basically, APRS is a packet system with the addition of a GPS (global positioning system) receiver. Many TNC's have GPS receiver inputs. There are stand alone GPS devices, which have map displays and tracker GPS units, which do not have map displays and are less expensive. GPS coordinates can also be manually entered into an APRS system. This is often done with fixed station operation. Weather stations can be interfaced with APRS to report live and up to date weather information over an APRS network.

There are several vhf radios and handi talkies that have built in TNC's and GPS receiver inputs. These type of radios allow you to automatically transmit an APRS beacon and use voice mode without changing any settings.

The universal frequency used for APRS is 144.390 MHz.

During emergencies, APRS can be very valuable. APRS can be monitored at an emergency operations center to track emergency response teams, mobiles, etc. Responders in the field can also see their own location.

QRM is a major concern in packet and APRS. It is important to use the minimum number of hops to get your message through. If you are a home station and know the digipeaters in your area, then program a specific path. For example: K2ABC, K2ABCD. Home stations should not usually use more than RELAY,WIDE. Mobile packet stations have about half the range than voice mode.

If you are a mobile, you should not need more than 2 to 3 hops. Mobiles usually use the path RELAY,WIDE because they may be out of range of a WIDE digipeater, but be near someone's home station acting as a RELAY. Wider ranges can be achieved by using the RELAY,WIDE,WIDE path.

In 1994, the WIDEn-n capability was incorporated in the Kantronics TNC's. The WIDE-n-n digipeater repeats any packet with the address of WIDEn-n, but only once. It keeps a copy of the last 30 seconds of packets, and compares each new packet that hears these last ones to avoid duplication. This method eliminates the multiple looping of packets caused by multiple generic paths such as WIDE,WIDE,WIDE, which can be as many as 21 copies. In a WIDEn-n network, there would only be three packets outward bound 3 hops.

The "n" in the WIDEn-n path indicates the number of hops. Each digipeater that repeats the packet, decrements the WIDE-SSID by one. So the -n decrements to zero, but the WIDEn portion indicates the original number of hops so that recipients know how far it traveled. A long distance traveler or special event of wide interest may use up to WIDE5-5 but a local commuter may only want to use WIDE2-2 to limit QRM. The advantage of the WIDEn-n routing is that every packet still only has one digipeater call.

It is important to know the first digipeater that a packet hit, not the last. Users should begin all packets with WIDE,WIDEn-n so that the first digipeater does a call sign substitution and the packet arrives as FIRST,WIDEn-n.

The Global Positioning System is maintained by the U.S. Department of Defense and consists of 25 satellites in orbit around the earth. Positioning information is determined by a small receiver which measures the time in micro-seconds that it takes to receive the broadcast from between 1-12 satellites. By receiving the signal from at least four satellites, position information down to about 10 meters can be determined. Altitude information can also be obtained from the system. In mobile situations you can determine speed and direction.

Below are some commands that should be made active:

- ECHO ON (normal) or ECHO OFF (if double letters are displayed)
- BEACON EVERY 0 (to manually enter beacons at base station)
- MONITOR ON
- MCOM ON
- MCON OFF (to display only packets addressed to you) or MCON ON (to display all packets)
- MRPT ON

APRS Hardware Configuration

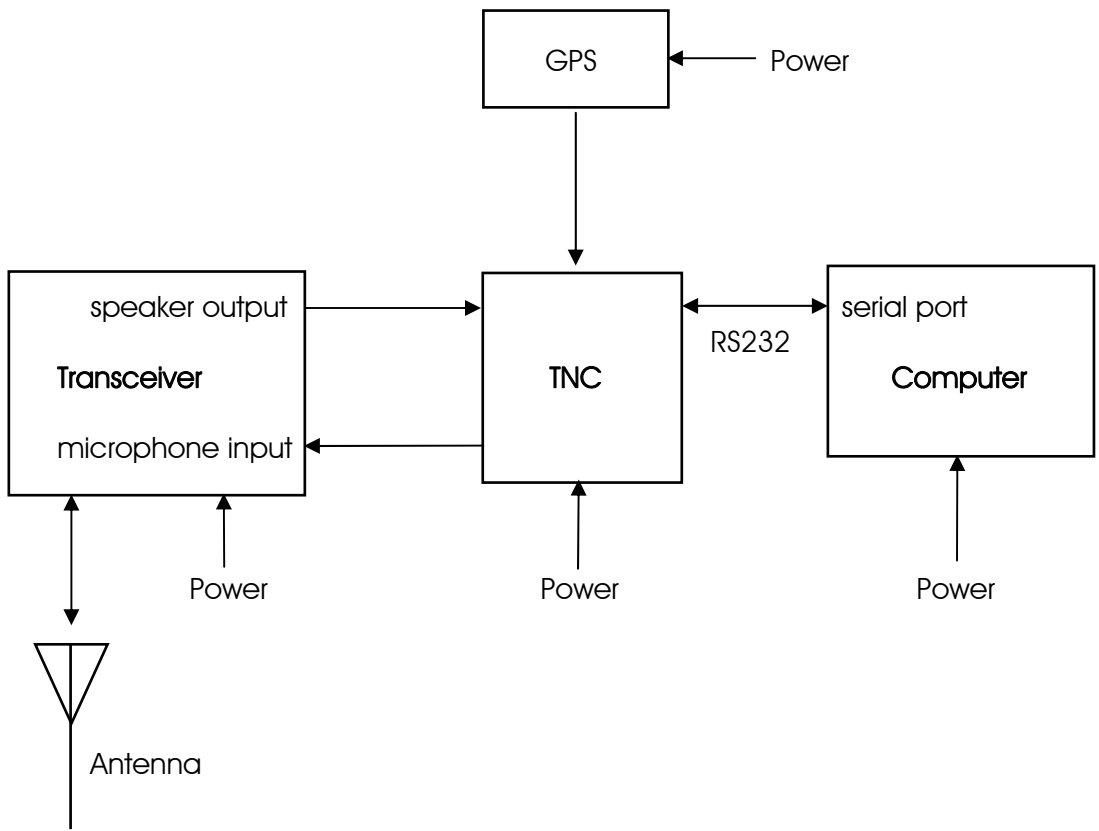

APRS Display Symbols (Icons)

The character after the latitude "N" in an APRS position report is a TABLE character and the character following the longitude "W" is the APRS symbol character. The TABLE character selects one of two symbol tables or may be used as a numeric overlay over some symbols as follows:

TABLE	RESULT
/	Primary symbol Table (Mostly stations)
\	Alternate symbol table (Mostly Objects)
0-9	Alternate NUMBERED symbol with 0-9 overlaid
A-J	Alternate NUMBERED symbol with A-J overlaid (!* also)

ALTERNATE SYMBOL TABLE: This alternate table consists of all of the weather symbols plus some new generic shapes for objects. Press F1-S in APRSdos to see these symbols. The numeral "3" is overlaid on those symbols which accept the NUMBERED overlays.

OVERLAY SYMBOLS: These symbols consist of the following shapes that can be overlaid with the numerals 0-9 and A-J (eventually A-Z). Select these from the OBJECTS-OVERLAY menu. These will only show on APRS78 or later.

CIRCLE, SQUARE, CAR, TRUCK, VAN, STAR(digits), DIAMOND(gates), Triangle

SYMBOLS WITH STAND-ALONE GPS TRACKERS: Since the stand-alone TNC trackers output the raw GPS data over the air, instead an APRS formatted position report, there are two methods for specifying the symbol type. First, by default SSID if no other vehicle data is available. See the table below.

SSID	SYMBOL
-0	Dot
-1	Ambulance
-2	Bus
-3	FireTruck
-4	Bike
-5	Yacht (sail)
-6	HELO
-7	Aircraft
-8	Ships (power)
-9	Car

-10	Motorcycle (Was a satellite in older versions)
-11	Balloons
-12	Jeep
-13	Rv
-14	Truck
-15	Van

These defaults can be user definable on a net by net basis. If your net must have different defaults, contact me.

Secondly, you may indicate the desired symbol character surrounded by braces {/\$} as the first 4 characters of the TNC BText. Once the BText has been received by a station, the mobile will then be displayed using the specified symbol. The advantage of this method is that more symbols are available than from the SSID convention. The disadvantage is that the symbol is not displayed until AFTER at least one BText is received. The old {\$} for only the primary table is still supported.

Symbol	PRIMARY SYMBOL TABLE (/)	ALTERNATE WX TABLE (\)
!	Police, Sheriff	EMERGENCY (!)
"	reserved (had been rain)	reserved
#	DIGI (white center)	NUMBERED STAR (green)
\$	PHONE	Bank or ATM (green box)
%	DX CLUSTER	
&	HF GATEway	NUMBERED DIAMOND
'	AIRCRAFT (small)	Crash site
(CLOUDY	CLOUDY
)	(was Mic-Rptr moved to /m)	
*	SNOW	SNOW
+	Red Cross	Church
,	reverse L shape	
-	House QTH	
.	X	
/	Dot	
0	Numeral circle	NUMBERED CIRCLE
1	Numeral circle	

2	Numeral circle	
3	Numeral circle	
4	Numeral circle	all of these are available
5	Numeral circle	
6	Numeral circle	
7	Numeral circle	
8	Numeral circle	
9	Numeral circle	Gas Station (blue pump)
:	FIRE	Hail
;	Campground	Park/Picnic area
<	Motorcycle	ADVISORY
=	RAILROAD ENGINE	
>	CAR (SSID-9)	NUMBERED CAR
?	SERVER for Files	INFO Kiosk (Blue box with ? in it)
@	HURRICANE or tropical storm	HURICANE
A	Aid Station	NUMBERED BOX
B	BBS	Blowing Snow
C	Canoe	Coast Guard
D		Drizzle
E		Smoke
F		Freezing rain
G	Grid Square (6 digit)	Snow Shower
H	HOTEL (blue bed symbol)	Haze
I	Tcp-Ip	Rain Shower
J		Lightening
K	School	
L	avail	Lighthouse
M	MacAPRS	
N	NTS Station	Navigation Buoy

O	BALLOON	
P	Police	Parking
Q	TBD	QUAKE
R	RECREATIONAL VEHICLE	Restaurant
S	SHUTTLE	Satellite/Pacsat
T	THUNDERSTORM	Thunderstorm
U	BUS	SUNNY
V	TBD	VORTAC Nav Aid
W	National WX Service Site	NWS site and W-R DIGI (green)
X	HELO (SSID-6)	Pharmacy Rx
Y	YACHT (sail SSID-5)	
Z	WinAPRS	
[RUNNER	Wall Cloud
\	TRIANGLE (DF)	
]	PBBS	
^	LARGE AIRCRAFT	NUMBERED Aircraft
_	WEATHER Station (blue)	WX and W-R DIGI (green)
`	Dish Antenna	Rain
a	AMBULANCE	
b	BIKE	Blowing Dust/Sand
c	tbd	
d	Dual Garage (Fire dept)	DX spot by callsign
e	HORSE (equestrian)	Sleet
f	FIRE TRUCK	Funnel Cloud
g	Glider	Gale Flags
h	HOSPITAL	HAM store
i	IOTA (islands on the air)	
j	JEEP (SSID-12)	WorkZone (Steam Shovel)
k	TRUCK (SSID-14)	

l	Area Locations (avail)	Area Locations (box,circles,etc)
m	Mic-Repeater	MILEPOST with 2 digit display
n	Node	NUMBERED TRIANGLE
o	EOC	small circle
p	ROVER (puppy)	Partly Cloudy
q	GRID SQ shown above 128 miles	
r	ANTENNA	Restrooms
s	SHIP (pwr boat SSID-8)	NUMBERED SHIP/boat (top view)
t	TRUCK STOP	Tornado
u	TRUCK (18 wheeler)	NUMBERED TRUCK
v	VAN (SSID-15)	NUMBERED Van
w	WATER station	Flooding
x	xAPRS (Unix)	
y -	YAGI @ QTH	
z		
{		Fog
	reserved (Stream Switch)	
}	diamond (open with dot in center)	
~	reserved (Stream Switch)	

AREA SYMBOLS! You can define BOX/CIRCLE/LINE or TRIANGLE areas in all colors, either open or filled in, any size from 60 feet to 100 miles. Simply move the cursor to the location, press HOME, move the cursor to the lower right corner of the AREA and hit INPUT-ADD-OBJECTS-AREA. Enter the type of area, and color. NOTE that AREA shapes can only be defined by selecting the upper left corner first, then the lower right second. The line is an exception. It is still top to bottom, but the lower point can be to the left of the beginning point.

These AREAS are useful for real-time events such as for a search-and- rescue, or adding a special ROAD or ROUTE for a special event. Be cautious in using the color fill option, since all other objects in that area that occur earlier in your PLIST will be obscured. AND you do NOT know the order of other stations P-lists.

AREAS FORMAT: The new format for specifying special areas uses the CSE/SPD field to provide the additional information as follows:

\$CSE/SPD... Normal Field description

lTyy/Cxx... Where: l (lower case l) is the symbol for "LOCATION SHAPES"

T is the Type of shape: 0=circle, 1=line, 2=elipse, 3=triangle, 4=box
add 5 to these => color-in

C is the color from 0 to 15. For colors geater than 9, the / is replaced with a 1.

yy is the sqroot of the latitude offset in 1/100ths

xx is the sqroot of the longitude offset

These offsets are ALWAYS positive to the right and down, except for the special case of a lower right quadrant line, these are given the Type of 6 and are drawn down and to the left.

NEW NWS WX SYMBOLS: With the new Alternate WX symbols table in version 7.8, old versions of APRS will see just lettered circles instead of the new symbols. Those older users may toggle the WX-DISPLAYS-OTHERsymbols to ON, to properly display these alternate NWS symbols.

HURRICANES, TROPICAL STORMS and DEPRESSIONS: These symbols will be differentiated by colors red, yellos, and blue. Additionally a radius of Huricane and also Tropical storm winds will also be shown if the format detailed in [WX.HTM](#) is used.

SYMBOLS ON MAPS! APRS can also be permanently embedded in maps. To embed a symbol in a map, simply make the first four characters of the label be a # followed by the dual symbol character, followed by a hex number from 1 to F that indicates the color for the symbol. The remaining 8 characters can be used for a conventional label at the same location. An example are the VORTAC nav-aids in Alaska. The Anchorage VORTAC appears as ANC on all maps below 128 miles. The label entry is #VFANC,LAT,LONG,128.

SUMMARY OF ALL RECENT SYMBOLS CHANGES

1. Moved all WX symbols to ALTERNATE table but still recognize both until primary table symbol is re-used.
2. In keeping with the idea of using the primary table where possible for active stations and the alternate table for OBJECTS, I also moved the following to the alternate table (again recognizing both until the primary is re-used:

!	Emergency (/! reused for police station)
L	Lighthouse
N	Navigation Buoy (/N reused for NTS station)
Q	Quake or bulls eye
V	Vortac
U	sunny (Sunny was \$, but prefer that for ATM or BANK)
l	area Locations
m	Milepost (/m reused for Mic-Repeater)

NUMBERED ICONS: Permits NUMBERing specific ICON shapes with a set of numerals and letters. The permitted labels are 0-9, !, ?, *, A-Z, and only the following alternate shapes will be numberable in this manner.

- 0 CIRCLE (does all of the existing lettered boxes, plus now numerals)
- A BOX (does all the numbered circles, plus now letters)
- # STAR (digipeaters)
- & DIAMOND (gates)
- > CAR
- n TRIANGLE
- s SHIP/BOAT
- ^ AIRCRAFT
- u TRUCK (big)
- v VAN

These labeled icons, then free up all of the primary ICONS 0-9 and A-J.
Recent Additions.

SYM PRIMARY		10 reusable WX, and 20 reusable letters/numerals
A	Aid Station	Blue box with white letter A?
!	Sheriff	Is a box with ! in it or a sheriffs badge?
H	Hotel	Blue box with white Bed
C	Canoe	canoe
g	glider	hang glider triangle
w	water H2O	box with H2O in it
t	Truck stop	
N	NTS traffic stn	ARRL diamond with NTS in it?
?	APRS File server	

SYM	ALTERNATE	53 available
`	Rain	Had been QUOTES but was difficult to handle
:	Driving Hail	back to back triangles
f	Funnel cloud Tornado symbol with FC on it	
[Wall CLOUD	?
\$	ATM	Green box with \$\$ in it
P	Parking	Blue box with P
R	Restaurant	Blue box with knife & fork
r	restrooms	Blue box with figures
X	Pharmacy	Rx
9	Gas	Blue box with gas pump (99.9 cents)
?	Info place	Blue box with ?